



# Ever-bigger? Car size at a crossroads

Increasing car size, and its impacts on urban space, road safety and resource use



24 June 2026

## Executive summary

### 'Carspreading': cars continue to grow in size

The average size of newly-sold cars keeps increasing every year. According to a new analysis of data covering the EU, UK and Norway by T&E and Clean Cities:

- The **average length of new cars keeps increasing by 1.2 cm a year**, and
- Their **average height keeps rising by 0.5 cm a year**.

These new findings complement previous work showing that new cars keep getting **0.5 cm wider every year** (2024), and that bonnet height keeps increasing by **0.5 cm every year** (2025).

### Car size at a crossroads: the current ever-bigger trend v. vehicle right-sizing

This study compares two scenarios for car dimensions over the period **2026 to 2040**. Under the **prevailing ever-bigger trend ('Current trend')**, the average size of new cars continues to increase in line with trends since 2000. Under a **more balanced scenario ('Right-sizing')**, the average size of new cars steadily returns to 2015 levels. Key findings for the period 2026 - 2040:

- **Parking:** Cities are set to lose 8.5% - 14% of their end-to-end on-street parking spaces by 2040 if the current ever-bigger trend prevails
- **Safety:** There are around 2,600 additional deaths of vulnerable road users by following the current ever-bigger trend, including 79 children. (By 2040, the increase in deaths of children walking widens to 40%.)
- **Electricity:** By 2040, the current trend would require an additional 22.5 TWh a year, comparable to 1,500 more onshore wind turbines (compared to Right-sizing), increasing annual household charging bills by €7 billion.

## Table of contents

---

### Section 1

#### 25 years of increasing car size

---

The increase in new car dimensions since 2000

### Section 2

#### Car size at a crossroads: Current trend v. Right-sizing

---

Two possible pathways to 2040

### Section 3

#### Analysis of impacts

---

Impact on on-street parking spaces, road fatalities, and resource consumption

### Section 4

#### Conclusion

---

And recommendations

### Section 5

#### Annexes

---

Methodologies and assumptions

## Section 1

---

# 25 years of increasing car size



# Size of new cars has increased steadily for more than two decades

While family size and car occupancy decrease\*, **the size of new passenger cars continues to increase across all key dimensions.** Vehicle dimension data since 2000 shows that:

- The average length of newly-sold cars is increasing by **1.2 cm a year**.
- Total vehicle height is increasing by **0.5 cm a year**.
- Vehicle width grew by an average of **0.5 cm per year** (T&E, 2024).
- Bonnet height is rising by **0.5 cm per year** since 2010 (T&E, 2025).

All other things being equal, **ever-bigger cars increase road safety risks, take up more space, heighten resource use, and increase running costs.**

\*Average family (household) size has fallen from 2.4 people per home in the late 2000s to 2.3 in 2025 (Eurostat), with projections suggesting further decreases to around 2 people per home by 2040. Car occupancy data from Germany shows a fall from an average of 1.54 people per car in the late 2000s to 1.46 in 2023, with similar downward trends in other countries.

## Average length and width

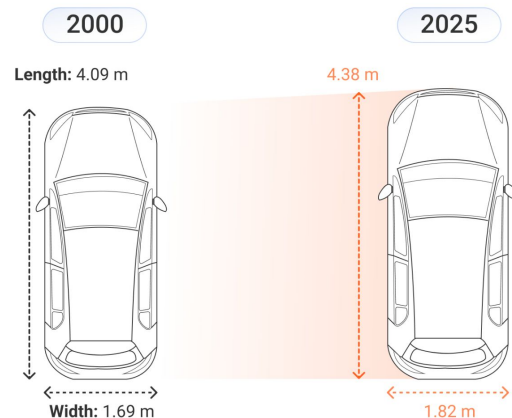

## Average bonnet height

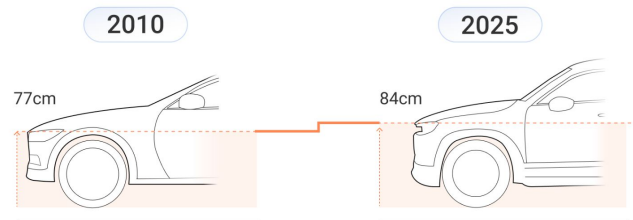

# Size of new cars keeps increasing: new findings (June 2026)

## Length

Evolution of vehicle length of newly sold cars

Vehicle length (m)

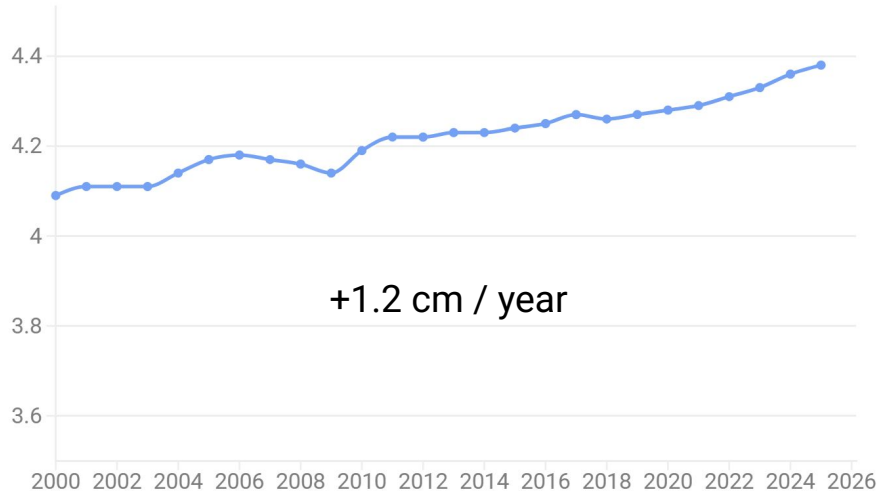

Source: Inovev, EEA, Dataforce • Excluding van body types. Scope: EU, UK and Norway.

## Total vehicle height

Development of total vehicle height of newly sold cars

Vehicle height (m)

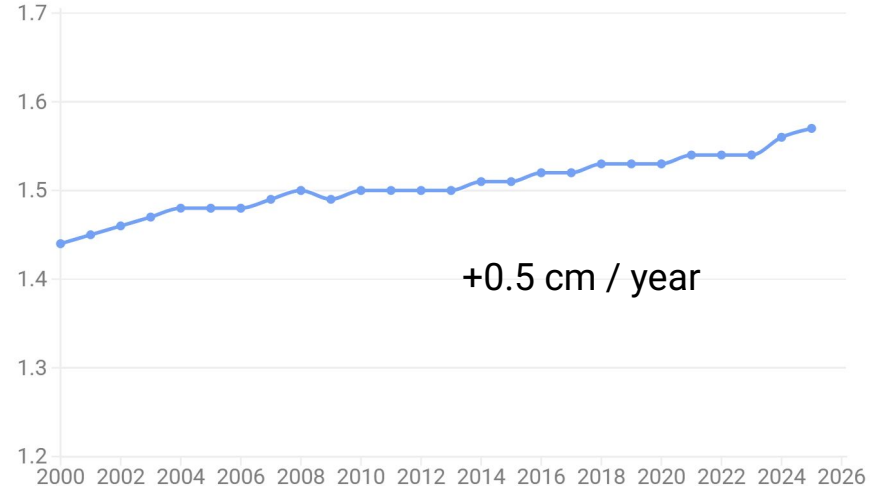

Source: Inovev, EEA, Dataforce • Excluding van body types. Scope: EU, UK and Norway.

# Size of new cars keeps increasing: findings from 2024 and 2025

## Width

Development of vehicle width of newly sold cars

Vehicle width (m)

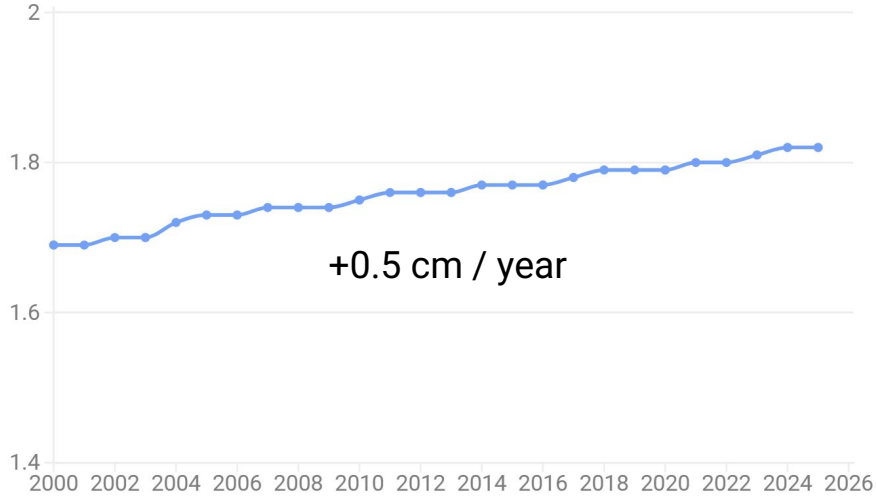

Source: Inovev, EEA, Dataforce • Excluding van body types. Scope: EU, UK and Norway

## Bonnet height

Bonnet height evolution of newly sold cars

Bonnet height (cm)



Sources: Euro NCAP, EEA, Dataforce • Excluding van body types. Scope: EU, UK and Norway.

## Section 2

# Car size at a crossroads



# Two futures for car dimensions: Current trend v. Right-sizing

Carmakers can pursue two very different pathways over the coming 15 years, 2026 to 2040. To illustrate this, **the report compares:**

- **A continuation of current trends:** lack of policies leads to a further growth in big cars. As a result, average vehicle dimension grow linearly. This is modelled by higher shares for C, D, and E-segment vehicles, and increased SUVisation across all segments.
- **Against a right-sizing scenario:** policies and incentives support smaller models (with increases in A- and B-segment cars, and a reduced share of SUVs). Average vehicle dimensions taper back to 2010-2015 levels by 2040.

*Scope is EU, UK & Norway. Methodology and assumptions are described in the Annex.*

## Average length and width

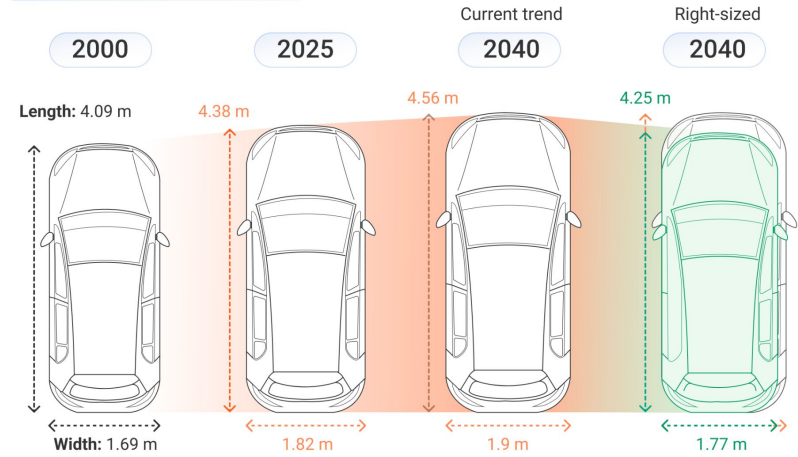

## Average bonnet height

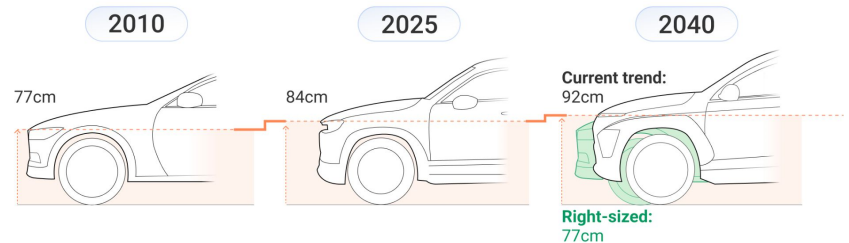

# Current trend continues v. Right-sizing scenario (1/2)

## Length

Future possible pathways for length of newly sold cars between 2026 and 2040

Vehicle length (m)

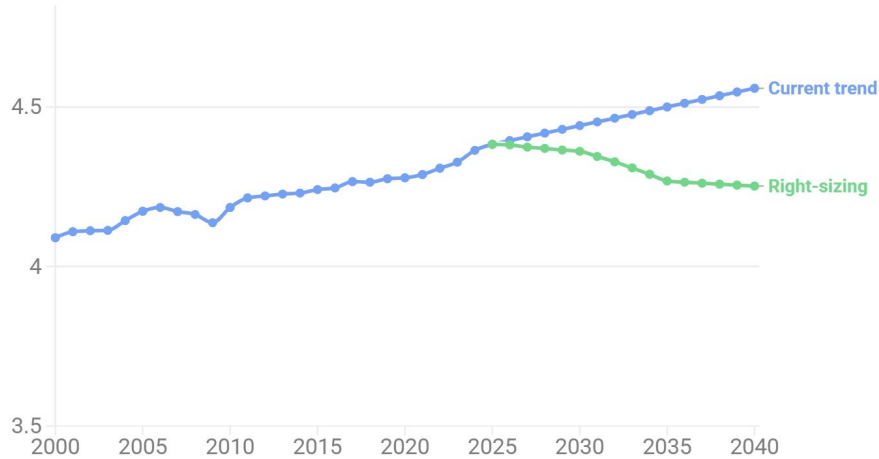

Sources: Inovev, EEA, Dataforce • Excluding van body types. Scope: EU, UK and Norway.

## Total vehicle height

Future possible pathways for height of newly sold cars between 2026 and 2040

Vehicle height (m)

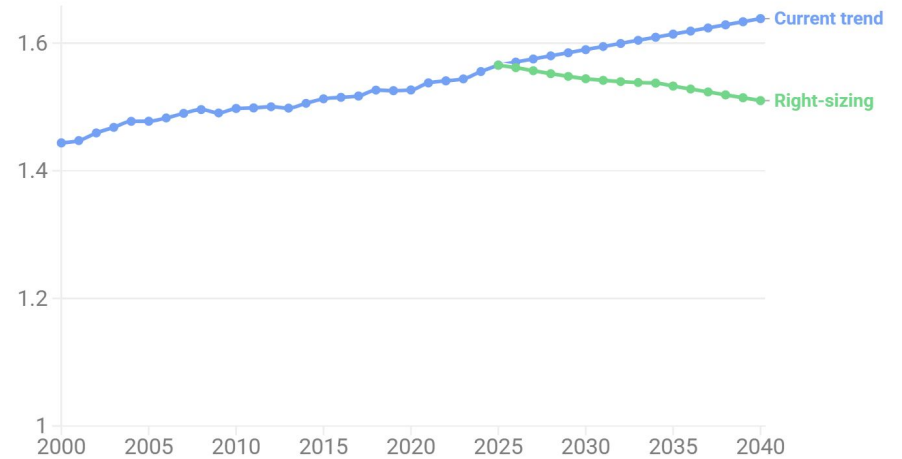

Sources: Inovev, EEA, Dataforce • Excluding van body types. Scope: EU, UK and Norway.

# Current trend continues v. Right-sizing scenario (2/2)

## Width

Future possible pathways for width of newly sold cars between 2026 and 2040

Vehicle width (m)

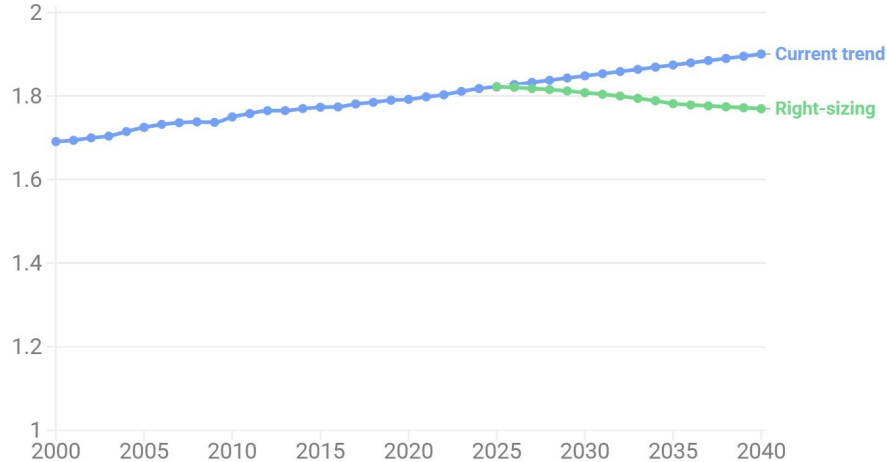

Sources: Inovev, EEA, Dataforce • Excluding van body types. Scope: EU, UK and Norway.

## Bonnet height

Future possible pathways for bonnet height of newly sold cars between 2026 and 2040

Bonnet height (cm)

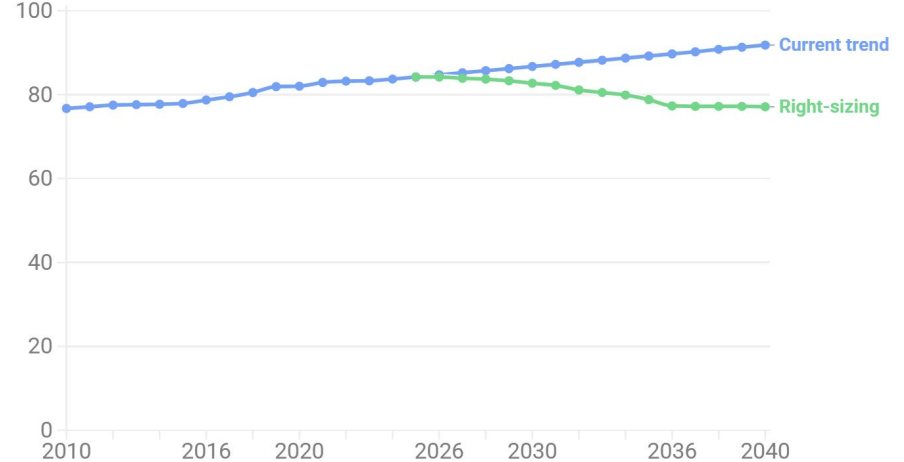

Sources: Euro NCAP, EEA, Dataforce • Excluding van body types. Scope: EU, UK and Norway.

## Section 3

---

# Analysis of impacts: Current trend v. Right-sizing



# Cities set to lose 8.5% to 14% of their on-street parking spaces by 2040 if the current trend to ever-bigger cars continues

**Longer and wider cars occupy more public space.** We analyse the impact for end-to-end on-street parking:

- As average car length increases, **the number of cars that fit decreases, reducing on-street parking spaces by 8.5% to 14%.**
- This range partly depends on the **profile of the street section**, together with assumptions around the willingness of drivers to manoeuvre cars into tight (and highly constrained) spaces.

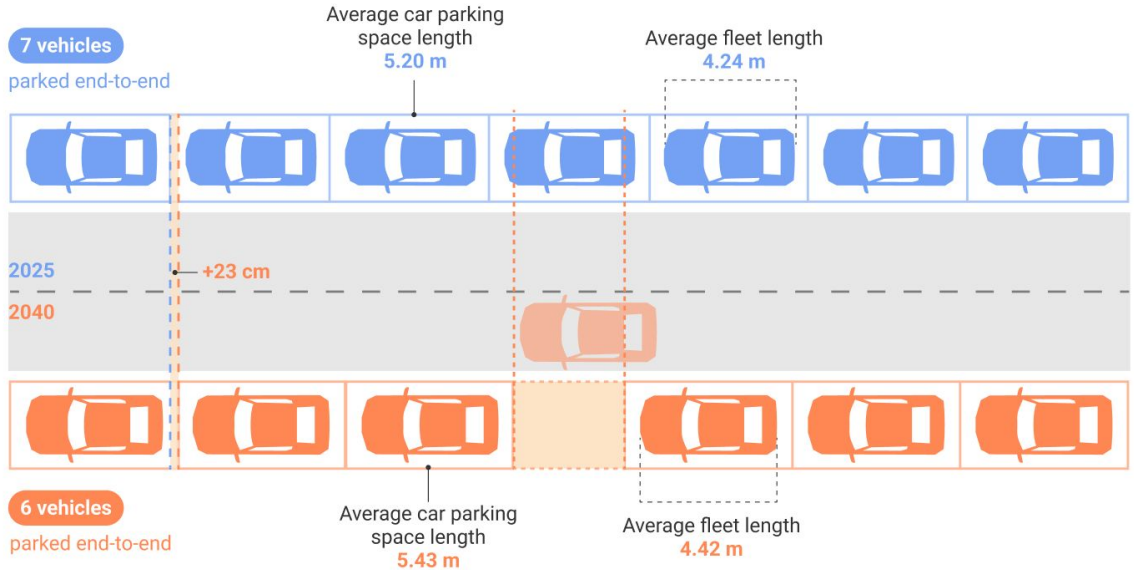

Source: VIZ Berlin, Inovev, T&E analysis

# Right-sizing is needed to protect urban space

- Right sizing is key to protecting urban space. If right-sizing is embraced, the average size of new cars entering the fleet is comparable to that of (older) cars being retired\*.
- **Right-sizing is vital for cities just to 'stand still' in terms of space allocation.** It ensures a relatively stable average car length across the fleet as a whole (see right).
- Without action to tackle the ever-bigger trend, the loss of parking could translate into support to convert other urban space to parking, **potentially reducing space available for pedestrians, cycling, nature and other public uses.**

\* The average car is retired after 20 years. Under the Right-sizing scenario, the average size of new cars steadily declines to match vehicles sold between 2010 and 2015. New cars entering the fleet therefore replace retiring vehicles of comparable size.

Future possible pathways for the car fleet's average length between 2026 and 2040

Fleet-average vehicle length (m)

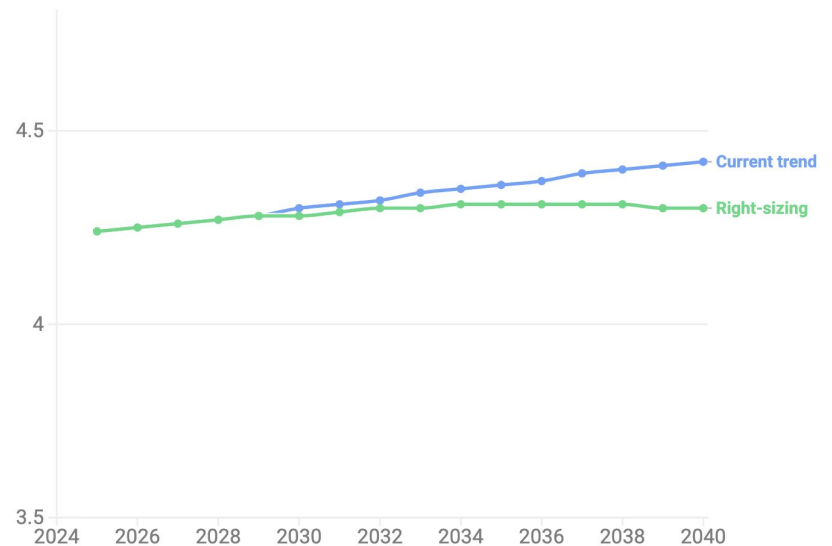

Sources: Inovev, EEA, Dataforce • Excluding van body types.

# Cities set for major on-street parking losses by 2040 under current trends

○ = 5000 end-to-end parking spaces ● Remaining parking ● Lost on-street parking spaces (-8.5% lower bound) ● Lost on-street parking spaces (-14% higher bound)

**London** -72,000 to -118,000  
Spaces at risk

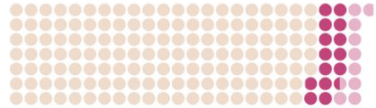

**Paris** -7,000 to -12,000  
Spaces at risk



**Madrid** -24,500 to -40,500  
Spaces at risk

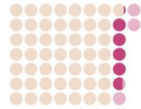

**Berlin** -71,000 to -117,500  
Spaces at risk

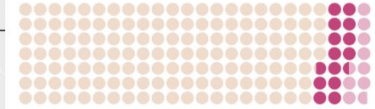

**Warsaw** -10,000 to -17,500  
Spaces at risk



**Rome** -58,000 to -95,500  
Spaces at risk

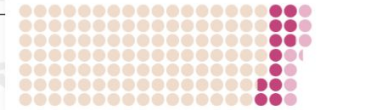

Source: T&E (2026) based on VIZ Berlin, Transport for London, Ayuntamiento de Madrid, WYG International, Paris en Selle, PUMS. Data available only for City of Paris, not the urban region. The city has already converted a large share of on-street parking to public use. Warsaw estimates based on 2009 data

# Yearly deaths of children widen to 40% higher by 2040 under current trends

Larger vehicles present increased risks to road safety for vulnerable road users, particularly children walking.

- Under current trends, **40% more children walking would be killed a year in car crashes by 2040** compared to the Right-sizing scenario (EU and UK). The gap rises through the 2030s, and in 2040, the ever-bigger trend would see 39 children\* killed, compared to 28 under a right-sizing scenario.
- For **vulnerable road users** (pedestrians, cyclists, motorcyclists and moped riders of all age groups) current trends would bring **400 additional deaths annually by 2040** compared to a more balanced scenario (14% higher). See next slide.

\*Children aged up to 14

Fatalities among child pedestrians following collisions with passenger cars under the 'Right-sizing' and 'Current trend' scenarios (2026 to 2040)

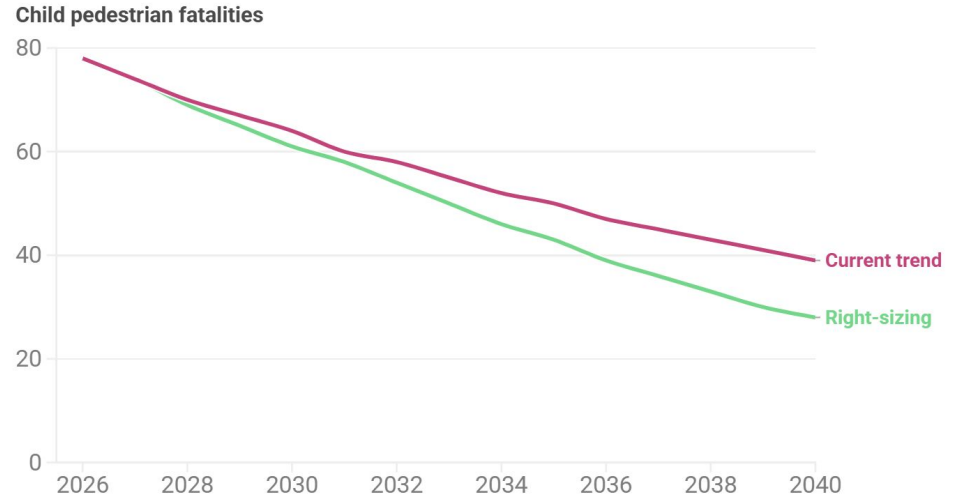

Source: T&E (2026) based on Eurostat, Department for Transport UK

# Right-sizing cars could save over 2,500 lives by 2040

Projected fatalities of vulnerable road users (pedestrians, cyclists, motorcyclists, moped riders)

Under current trends Under 'right-sizing' scenario Difference

## Fatalities

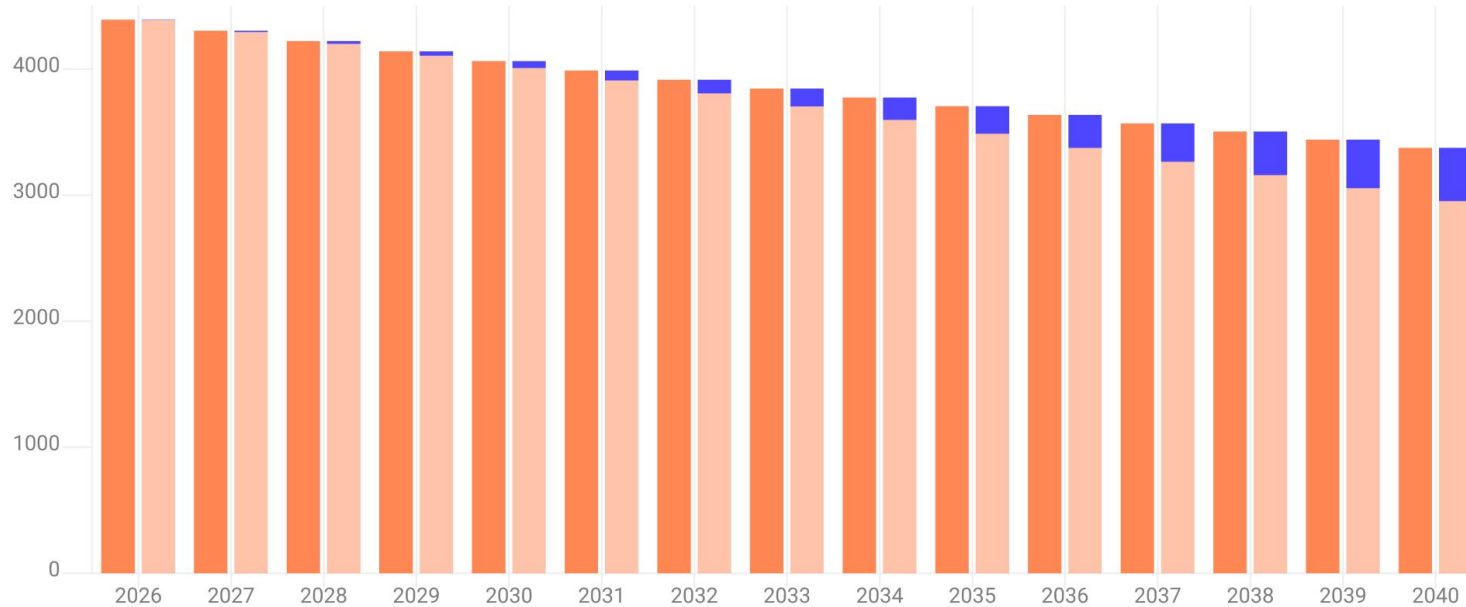

Source: T&E (2026) based on Eurostat, Department for Transport UK

# Right-sizing cars could save over 400 lives in 2040

Projected fatalities of vulnerable road users (pedestrians, cyclists, motorcyclists, moped riders) in 2040

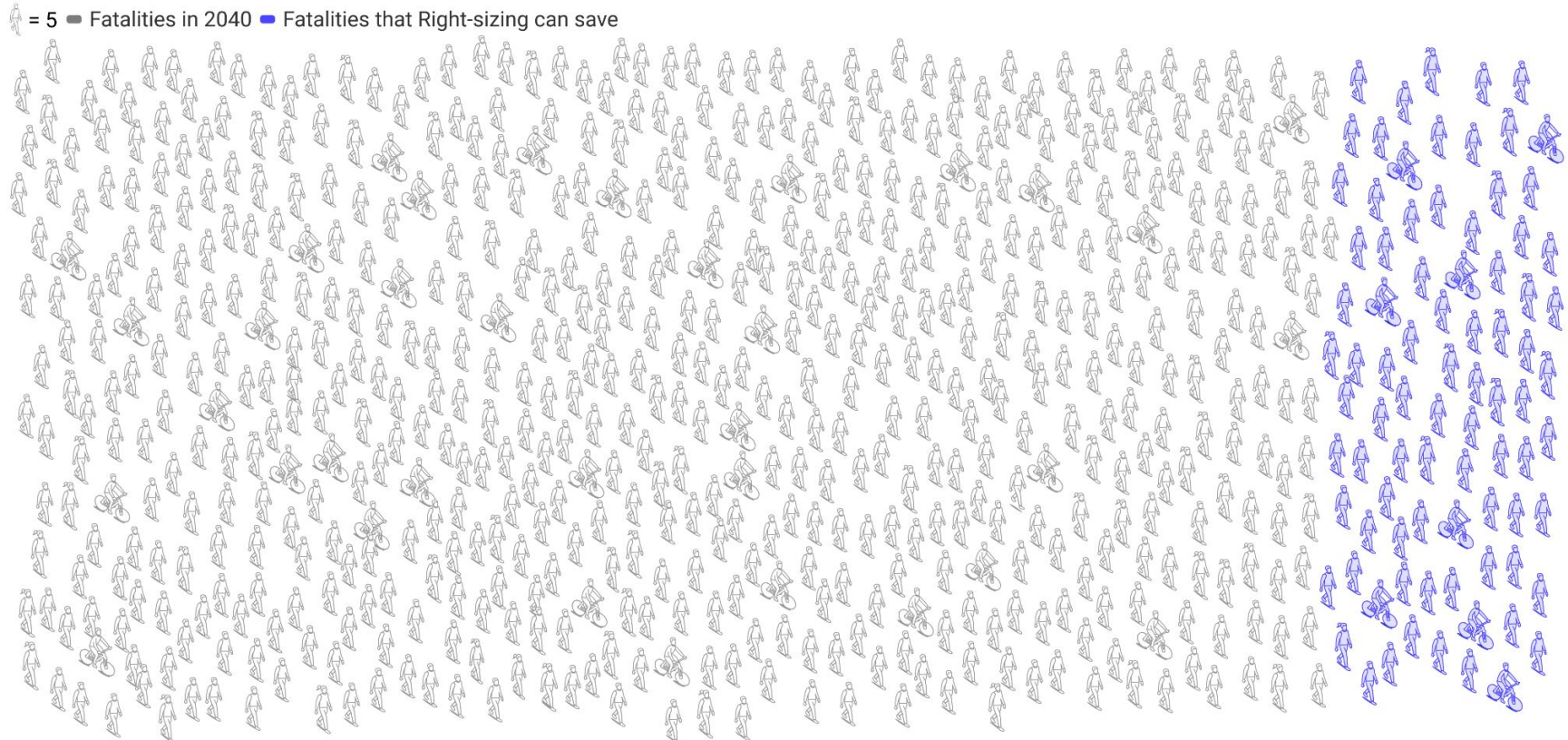

Source: T&E (2026) based on Eurostat, Department for Transport UK

# How bigger cars lead to more road deaths (methodology)

## Higher bonnets increase risk of VRU fatalities:

- The [2023 VIAS study](#) linked a 10 cm increase in bonnet height to a 27% higher risk of VRU fatalities in crashes.
- Under the Right-sizing scenario, fleet average bonnet height has moderated to 80.6 cm by 2040, and the application of the VIAS finding implies that approx 1.42% of VRU crashes would result in a fatality.
- If current trends continue, however, fleet average bonnet height would rise to 86.2 cm by 2040, with 1.63% of VRU collisions resulting in a fatality.
- The difference in deaths over the period is 2,570 (including 400 in the year 2040).

## Higher bonnets have a more pronounced impact on child fatalities:

- Higher bonnets impose graver risks on children. In the apparent absence of European data quantifying these more severe impacts on children, this study takes US research ([Tyndall, 2024](#)) as being the best currently available. It links a 10 cm bonnet height increase to an 81% increase in fatality risk for child pedestrians
- By 2040, fleet average bonnet height of 86.2 cm under current trends is linked to a 0.67% risk of death for children walking hit by cars. This is markedly above the comparable risk of 0.48% under the right sizing scenario where fleet average bonnet height has moderated to 80.6 cm
- The difference in deaths over the period is 79 (including 11 in the year 2040).

# Ever-bigger cars use more energy, piling pressure on power grids

**Larger cars need more energy.** Additional electricity generation is required for EVs, with families locked into higher costs:

- A continuation of the **current trend to ever-bigger cars** would require more electricity compared to Right-sizing;
- By 2040, Europe (EU & UK) would need an additional 1,500 wind turbines (averaging 5 MW each) to serve a 22.5 TWh gap between Current trends and Right-sizing (see right);
- There would be a rising burden on European electricity grids, many of which are already stretched;
- Cumulatively, the additional electricity required to 2040 is 116 TWh without changes to current trends. This additional power requirement adds **€36 billion** to household recharging bills across the EU and UK over the period 2026 to 2040 (**€7 bn** in 2040 alone).

Current trend will require an additional 116 TWh in electricity demand until 2040

Additional electricity consumption compared to 'right-sizing' (TWh)

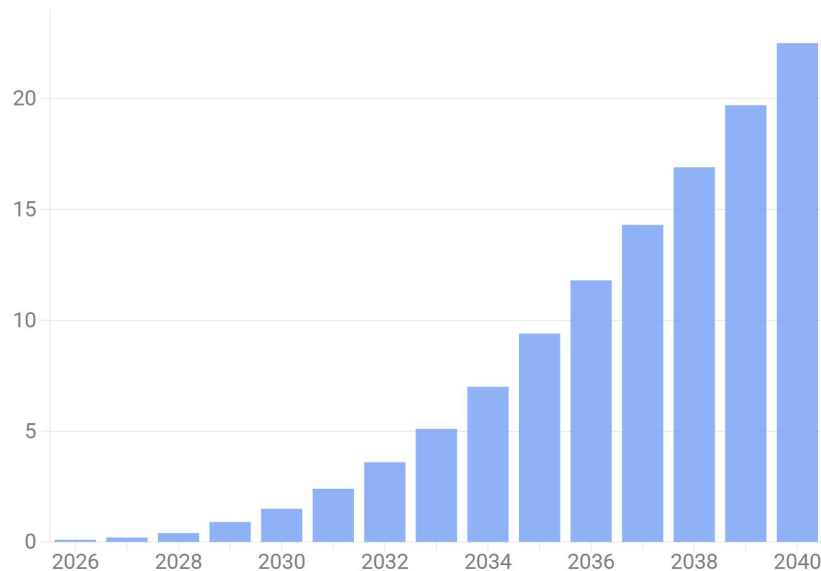

Source: T&E (2026) based on Eurostat and EV Database • Annual mileage assumed at 12,000 km.

# Bigger cars would cost Europe >100m additional barrels of imported oil

**Bigger cars mean higher oil dependence** as combustion cars continue to dominate the fleet in the period 2026 to 2040:

- If current trends continue, an additional **100 million barrels** of oil imports would be needed by 2040;
- If the car CO2 law is weakened further, an **additional 140 million barrels of oil imports would be needed**. Based on average 2021-25 oil prices, this would translate into **nearly €10 billion**;
- This is roughly equivalent to Germany's total oil import bill for its entire passenger car fleet in 2025.

Additional oil imports under the current trend scenario compared to right-sizing between 2026 and 2040.

Additional barrels of oil imports (v. 'right-sizing')

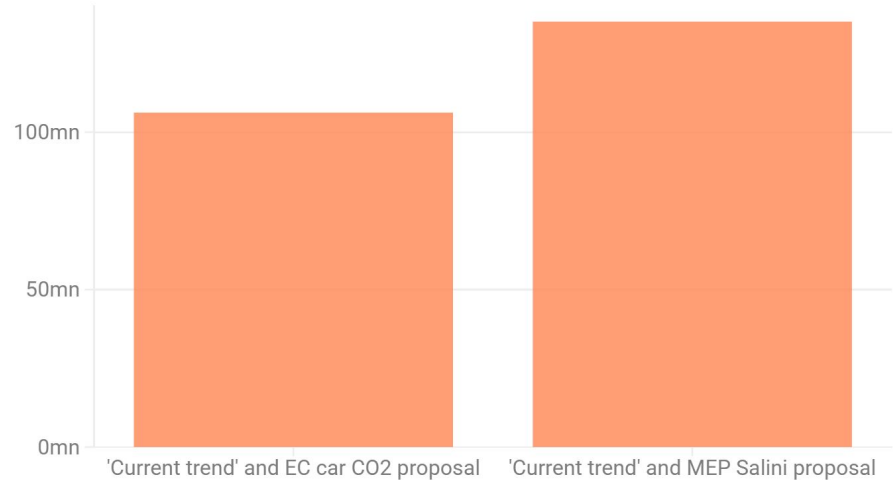

Source: T&E (2026) based on Inovev, EEA, and EUTRM

## Conclusion

# Ever bigger cars: where does it stop?

Relentless carspreading highlights critical questions for Europe: where does it stop? When does it stop? If left unchecked, the average new car by 2040 will balloon to an estimated 4.56 meters long and 1.90 meters wide, up from 4.09 meters by 1.69 meters in 2000. This trajectory is deeply regressive, compromising public safety, eroding urban space, and inflating household energy bills.

It is entirely possible to bend this curve and transition to a balanced, right-sized vehicle fleet, but doing so requires swift and decisive political action. The evidence is undeniable. Now is the time to protect public safety, shared space, and Europeans under pressure from ever-bigger bills.

To succeed, policymakers must deliver a coordinated, multi-level response. The EU must establish meaningful dimensional limits that end the mimicking of US-style mega-SUVs, and their importation. At the same time, national governments need to reform registration and circulation taxes to disincentivise oversized vehicles, while local authorities must deploy fairer, size-focused parking charges to safeguard public space.

**If policymakers don't take action to curb the ever bigger trend, the regressive impacts will continue to increase.**

### Policy action to curb ever-bigger cars:

- 01** Cap bonnet height in new cars at 85 cm, and limit width to 192 cm (EU level, and UK)
- 02** Add vehicle dimensions to vehicle registration certificates (national governments / EU)
- 03** Ensure that regulatory advantages only go to small electric cars (not longer than 4.2 metres) in revising car CO2 law (EU)
- 04** Rate the vision of children from the driver's seat of new cars (Euro NCAP), and apply a **Child Vision Standard in law** (EU, and UK)
- 05** Vary car taxes and parking charges by dimensions (national governments, and cities)

## Acknowledgements

Report published:

Analysis: Sofía Navas Gohlke

Author: James Nix

Infographics: Cristina Pita, Federica Pasquini

Contributors / advisors: Lucien Mathieu, Oliver Lord, Jens Müller, Laurence Peplow, Eoin Bannon

Editeur responsable: William Todts, Executive Director

© 2025 European Federation for Transport and Environment AISBL

### To cite this report

Transport & Environment (2026), Ever-bigger? Car size at a crossroads.

### Acknowledgements

The findings and views put forward in this publication are the sole responsibility of the authors listed above.

T&E thanks reviewers of earlier drafts, noting that the responsibility for the report remains with T&E, and that such reviews are confined to methodology, and do not cover conclusions or recommendations.

T&E and Clean Cities Campaign gratefully acknowledge the support given by the FIA Foundation for our work on the dimensions of light duty vehicles.

### Further information

[www.transportenvironment.org](http://www.transportenvironment.org) | [BlueSky](#) | [LinkedIn](#)

# Reform measures that contribute to Right-sizing

### Vehicle standards at EU / UK / UNECE level

- Bonnet height in new cars is capped at 85 cm, and width limited to 192 cm, applied to new type approvals from 2033 and all new cars sold from 2036
- In rating the safety of new cars, Euro NCAP applies a Direct Vision test to improve the visibility of young children from the driver's seat as soon as possible.
- A minimum Child Vision Standard is applied in EU and UK law

### National tax reform

- More countries reform taxes to more effectively discourage larger cars in favour of smaller models

### City parking charges, and similar local reforms

- Cities vary parking charges to tackle car size. Reform of local taxes also has a key role to play, for cities or regions that have such powers

### Action by vehicle-makers

- More car-makers start to produce and actively market cars with bonnets 60 cm to 75 cm high (in line with good design practice), and which are no more than 4.2m long, 1.8m wide and 1.6m high

*Note: while measures here contribute to Right-sizing, this report does not assess the extent of their contribution.*

# Scenario building (1/2)

The scenarios project how car dimensions could evolve to 2040 under two contrasting pathways: a continuation of current trends, and a shift towards more reasonably-sized vehicles. The scope of the analysis is the EU, Norway and UK.

### Scenario following current trends

- **Historical increases** in vehicle dimensions (new sales) have been **broadly linear** over recent decades
- Assumes **continuation of these trends to 2040** using historical growth rates (past ten years as reference for bonnet height, past 25 years for all other dimensions)

Average dimensions of new sales	2000	2005	2010	2015	2020	2025	2040 CT	2040 RS
Bonnet height (cm)	-	-	76.7	77.9	82.0	84.2	91.8	77.1
Length (m)	4.09	4.17	4.19	4.24	4.28	4.38	4.56	4.25
Width (m)	1.69	1.73	1.75	1.77	1.79	1.82	1.90	1.77
Total vehicle height (m)	1.44	1.48	1.50	1.51	1.53	1.57	1.63	1.51

# Scenario building (2/2)

## Scenario achieving reasonably sized vehicles: Right-sizing

- Based on **projected powertrain mix** under the **European Commission's car CO2 proposal** (December 2025)
- Combines:
  - BEV segment distribution gradually converges with ICE distribution by 2035
  - **Small car segments** (A/B) attain their **historical** (2010-25 for ICE and HEVs, 2019-25 for BEVs) **maximum shares by 2035**
  - Segment distribution of larger vehicles (C/D/E) in 2035 is aligned with industry forecasts
  - The **car/SUV split** is assumed to **shift towards cars**, reaching the historical maximum of the car body type by 2035. This split is calculated separately for each powertrain and segment
  - **From 2035** onwards, **average height and width** for each segment, sub-divided by body type, **gradually decline**, reaching historical minimum levels by 2040. This reflects “bottom-up” pressure from national measures (e.g. taxes and charges varied by size or weight)
  - For **width**, a **cap of 1.92 m** is assumed, which applies to new type approvals from 2033 and all new sales from 2036
  - A **bonnet height cap of 85cm**, which applies to new type approvals from 2033 and all new sales from 2036

# Safety analysis

The impact of higher bonnets on fatalities among vulnerable road users (VRUs) and child pedestrians was estimated using historical collision trends in the EU and UK, and scientific evidence linking higher bonnets to increased fatality risk in crashes.

- Fleet-average bonnet height calculated using T&E's in-house fleet turnover model
- **UK Department for Transport collision and fatality data** used to analyse **historical collision and fatality trends** involving VRUs, children, and passenger cars.
- UK fatality rates and [EU collision matrix](#) applied to **estimate total EU collisions** involving passenger cars and both VRUs and children for 2010-2025 (as no EU-wide collision totals are publicly available)
- Historical **decline in collisions** between passenger cars and VRUs/children **assumed to continue** through 2040
- **Increased fatality risk** after a collision with a passenger car **associated with higher bonnets** calculated using [VIAS \(2023\)](#) for VRUs and, for children, [Tyndall \(2024\)](#), being the best studies currently available respectively
- **Annual fatalities for 2026-2040 calculated** based on: projected collision numbers, projected fleet-average bonnet height, fatality rates associated with change in fleet-average bonnet height
- All other factors being equal, wider cars present a higher collision risk than narrow models. However, this was not included in our analysis due to the apparent absence of literature quantifying the increased danger of greater width
- All other factors remain equal, i.e. all new cars remain subject to the same vehicle safety standards

# Parking analysis (1/2)

The estimated loss of end-to-end on-street parking space is calculated by combining projected increases in vehicle length with detailed spatial data on public on-street parking spaces in Berlin.

- **Fleet-average length calculated** using T&E's in-house fleet turnover model
- Average end-to-end parking space length in 2025 assumed at 5.2 m, based on [Berlin Traffic Information Centre](#) data.
- Required manoeuvring space derived from the relationship between average fleet length in 2025 and end-to-end car parking space length. This **ratio of car length to manoeuvring space is assumed to remain constant over time**, meaning longer vehicles require proportionally more parking space
- Analysis of potential loss of public end-to-end on-street car parking space is based on [2023 Berlin parking data](#). **Only publicly accessible end-to-end parking spaces** are included, excluding loading and short-stay / temporary zones (68% of total on-street parking spaces). The final data set covers approximately **838,800 end-to-end parking spaces**
- Parking capacity for each street segment recalculated using projected car lengths under the Current trends scenario to 2040. To avoid overstating parking losses, the **capacity reductions are only counted if more than 50% of the manoeuvring space for the final vehicle is lost**
- All other factors are assumed to remain the same, with no differences between scenarios (e.g. steering geometry)

### Parking analysis (2/2)

- Whether an additional vehicle can be accommodated depends on where a free space sits within a street segment. **End positions offer more manoeuvring flexibility**, and the analysis accounts for this, yielding a range in the reduction of end-to-end parking spaces (8.5% to 14%), **depending on local conditions** at the segment ends (e.g. driveways offer more flexibility to enter/exit a space, compared to fixed obstacles such as trees or kerbs).
- The **estimate for other major European cities** was built in three steps: (i) identifying the total stock of public on-street parking spaces, (ii) assuming the share of end-to-end parking matches Berlin's, given the absence of more granular city-level data, and (iii) applying the Berlin reduction range of 8.5% to 14% to the resulting end-to-end parking estimate.
- There are different configurations of on-street parking: end-to-end, perpendicular, diagonal. As this analysis is confined to end-to-spaces, we remove other on-street spaces. In Berlin the relevant figure for end-to-end spaces is 68%. For cities **where a breakdown of the different types of on-street spaces was not available**, we apply Berlin's figure. **In such cities**, the number of end-to-end on-street parking spaces at risk **may be underestimated** as the German capital has a high share of wider streets, which more often accommodate perpendicular and diagonal parking.
- The sources for the parking studies relied on for the 6 cities covered here are listed in the infographic above. For each city, the overall total was taken from the relevant report in each case, **except for Madrid**, where the estimate for the metropolitan area was shared one-to-one by Ayuntamiento de Madrid, **and Rome**, where the estimate is based on figures for the urban road network published by PUMS.

# Electricity consumption analysis

- **BEV fleet turnover** is modelled using T&E's in-house fleet turnover model
- The number of new BEVs is based on the **European Commission's car CO<sub>2</sub> proposal** published in December 2025. This enables the calculation of BEVs' average fleet dimensions between 2026 and 2040 under both the 'Current trends' and 'Right-sizing' scenarios.
- Using vehicle data from EV Database, a **linear regression** was used to establish the **relationship between electricity consumption and vehicle dimensions** ( $R^2 = 0.75$ ). Charging losses were accounted for, and annual efficiency improvements of 0.5% were assumed.
- Combining projected BEV fleet dimensions with the estimated relationship between car size and electricity consumption allows calculation of **average BEV electricity consumption between 2026 and 2040 in both scenarios**.
- **Total electricity consumption** is derived from the projected BEV fleet size and average vehicle electricity consumption.
- Private charging prices in 2040 are assumed to remain at 2025 levels (taken from Eurostat). Public charging is assumed to account for 20% of charging demand, with AC and DC ad-hoc charging prices are based on EAFO data from December 2025.
- Annual vehicle mileage is assumed to be 12,000 km.

# Additional oil consumption

- **ICE fleet turnover** is modelled using T&E's in-house fleet turnover model, enabling calculation of average car length, width, and height of the ICE fleet between 2026 and 2040.
- The **share of ICE vehicles** in the total fleet is based on the **European Commission's car CO<sub>2</sub> proposal** published in December 2025. The scenario reflecting **MEP Salini's proposal**, which results in a higher number of ICE vehicles entering the fleet between 2026 and 2040, was also modelled.
- Using EEA emission data and Inovev vehicle dimension data for 2010 to 2023, a Weighted Least Squares (weighted by registrations) **regression** was used to establish the **relationship between vehicle emissions and dimensions** ( $R^2 = 0.44$ ). A 19% gap between official and real-world emissions, based on historical [real-world data](#), was assumed to persist until 2040.
- Total fleet emissions were calculated based on average vehicle emissions, and using the projected share of petrol and diesel ICE vehicles the emissions were subsequently **converted into barrels of crude oil needed**.
- This has been done for both dimensional scenarios ('Current trends' and 'Right-sizing')

## Images from previous car size reports are available via T&E's [website](#)

Higher bonnets more often knock pedestrians under the vehicle rather than deflect them

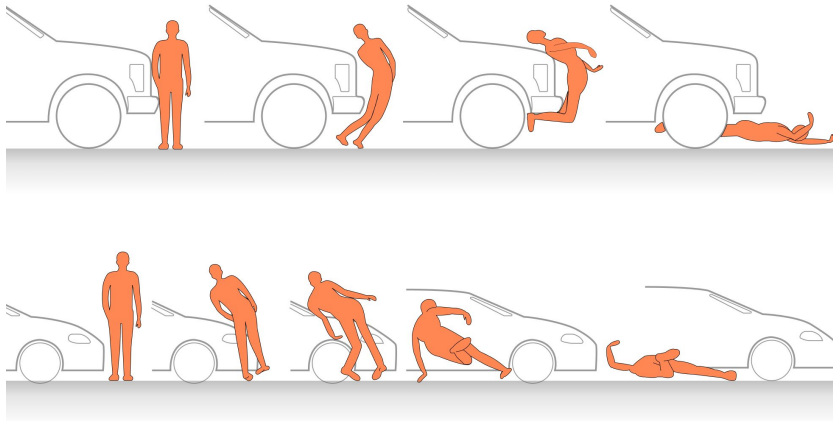

Source: Ptak (2019). A new method to assess pedestrian kinematics. Transport, Vol 34 Issue 1. These images reflect collisions in urban areas where 70% of pedestrian fatalities are recorded (typical speed < 50 km/h)



The higher the bonnet, the bigger the blind spot:  
More high-fronted SUVs would mean more children drivers don't see

RAM TRX

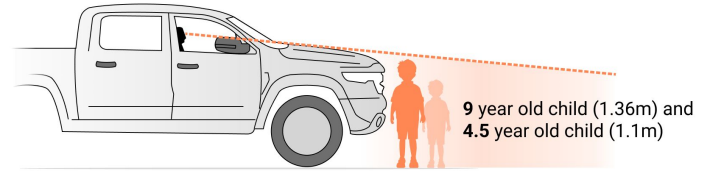

Land Rover Defender

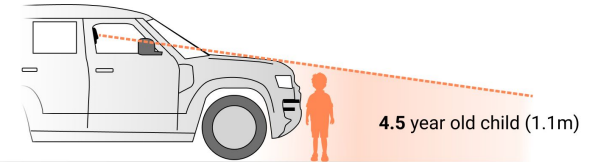

VW Golf

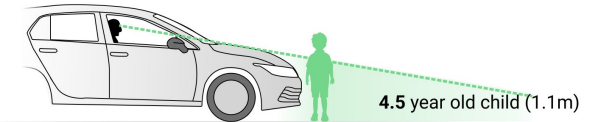

Analysis based on children of average European height standing to the centre of vehicle fronts. Drivers are of average European adult height. Vehicle assessment and modelling by Summerskill / Loughborough University SDCA (2025)



# Outsized SUVs leave too little space for other road users

Average new car width: 180cm (200cm with mirrors)

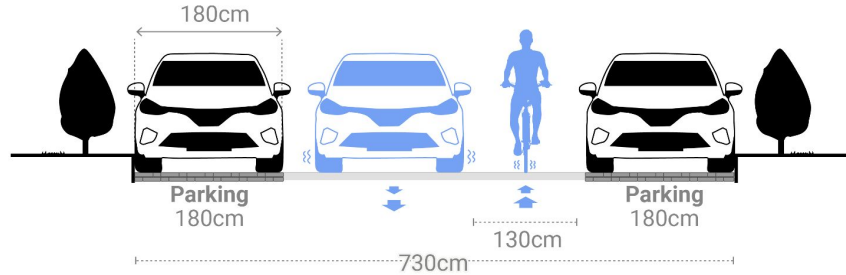

Mega SUV width: 200cm (220cm with mirrors)

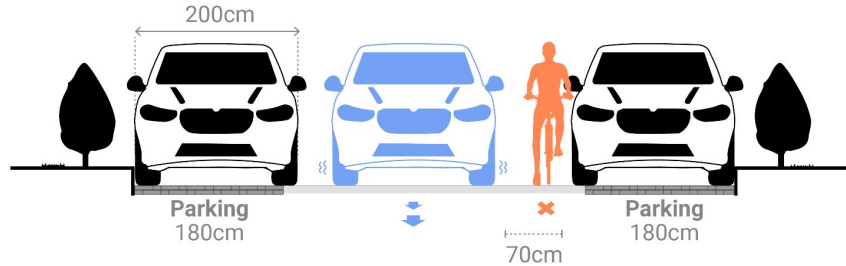

Source: T&E 2024. Notes: Image shows a residential street with cycling in both directions, one way for all other traffic, and parking for vehicles on both sides. A 730 cm width is frequently used for such streets in Europe.